

Data sheet

TempEvent



Image similar (contains options)

STANDARDS

Low-temperature tests

IEC 60068-2-1, Test A

ISO 16750-4, Low temperature

ETSI EN 300019-2-4, Test Ab/Ad

MIL-STD-810 G, Meth. 502.5

JESD22-A119

High-temperature tests

IEC 60068-2-2, Test B

ISO 16750-4, High-temperature test

ETSI EN 300019-2-4, Test Bb/Bd

MIL-STD-202 G, Meth. 108A

MIL-STD-810 G, Meth. 501.5

MIL-STD-883 J, Meth. 1008.2

JESD22-A103D

Alternating temperature tests

IEC 60068-2-14, Test Nb

ISO 16750-4, Temp. steps

ISO 16750-4, Temp. cycling

ETSI EN 300019-2-4, Test Nb

MIL-STD-331 C, Test C6

JESD22-A105C

The temperature values specified in the standards (severity levels) are limited by the highest and lowest test space temperature. The choice of the appropriate test system depends on the temperature change rates during alternating tests. The requirements are met if the test system capacity is large enough to compensate for the influence of the specimen and its heat dissipation in the relevant capacity range. Please contact us to test the feasibility with your test specimen.

The reference point for test values and tolerance specifications is the middle of the test space. Verifying documentation for individual test values is optionally available at additional cost.

Your standard is not listed? Contact us!

FUNCTIONAL DIAGRAM

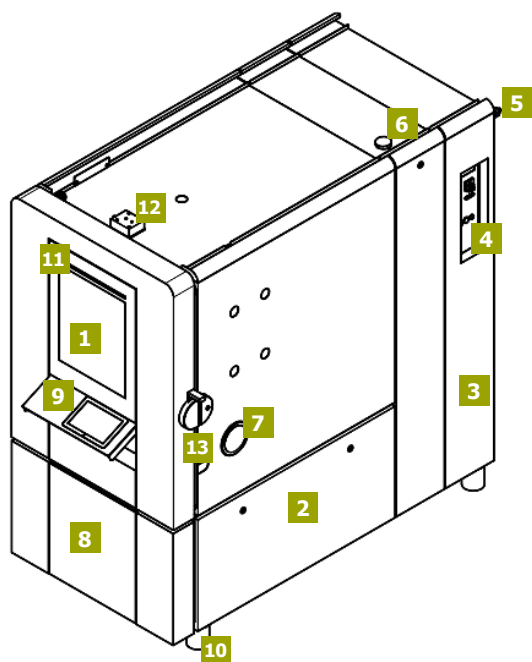

- 1** Test space, test space door
- 2** Machine part
- 3** Power supply unit, control cabinet
- 4** Master switch panel
- 5** Power supply
- 6** Pressure equalization port
- 7** Stainless steel access port
- 8** Front panel
- 9** Webpanel including WEBSeason®
- 10** Adjustable vibration absorbing feet
- 11** LED status bar
- 12** Heat sink for LED test space illumination
- 13** Test space door and door lock

DESIGN VERSIONS

The various design versions of the new ClimeEvent differ fundamentally in terms of their size (test chamber volumes and dimensions). In addition, there are options available for selected design versions. These options can be found starting on *page 7* of the technical specification.

Size 180 l

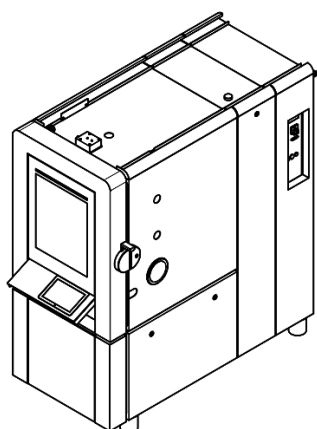

Size 340 l

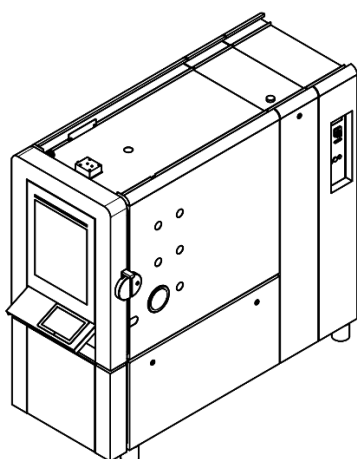

Size 600 l

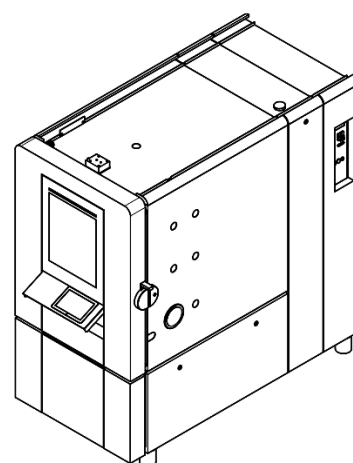

INSTALLATION DRAWINGS

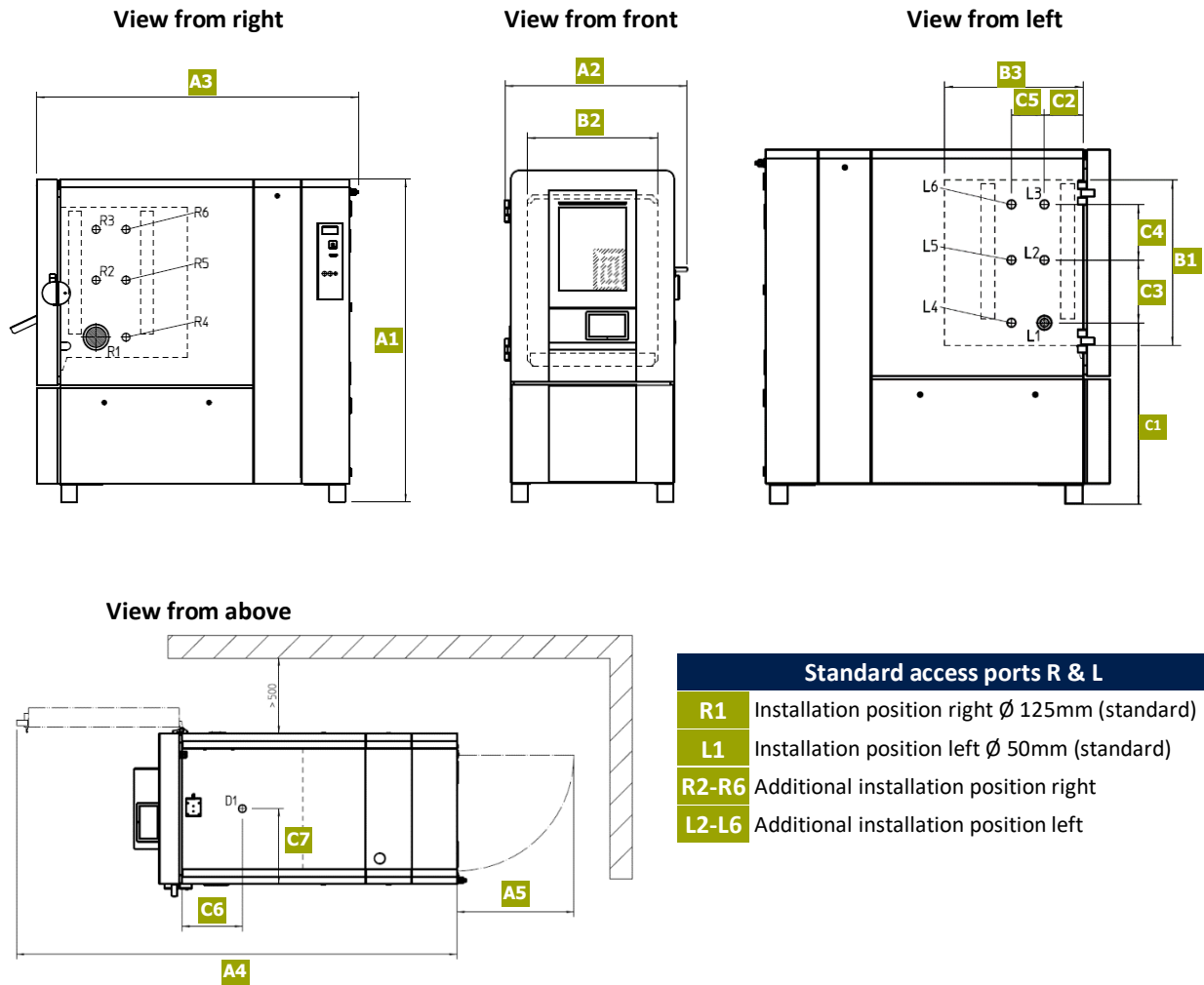

		A1	A2	A3	A4	A5	B1	B2	B3	C1	C2	C3	C4	C5	C6	C7
		Test chamber					Test space			Standard access ports R & L ²⁾						
		Dimensions in mm														
180	3 K/min	1830	900	1575	2369	560	750	580	450	1030	225	250	250	-	230	390
	5 K/min	1830	900	1890	2677	560	750	580	765	1030	225	250	250	170	380	390
340	3 K/min	1830	900	1890	2677	560	750	580	765	1030	225	250	250	170	380	390
	5 K/min	1830	900	1890	2677	560	750	580	765	1030	225	250	250	170	380	390
600	3 K/min	2050	1120	1925	2939	777	950	800	800	1040	225	360	320	190	400	500
	5 K/min	2050	1120	1925	2939	777	950	800	800	1040	225	360	320	190	400	500

1) Overall external dimensions when erected

2) Only the standard access ports R1-R3 and L1-L3 are available for the 180 liter versions

TECHNICAL DATA | Temperature change rate: 3 K/min

		T2/180/40/3	T2/180/70/3	T2/340/40/3	T2/340/70/3	T2/600/40/3	T2/600/70/3			
DIMENSIONS, LOAD, WEIGHT										
External dimensions (HxWxD) approx.	mm	1830	900	1575	1830	900	1890	2050	1120	1925
Test chamber dimensions (HxWxD) approx.	mm	750	580	450	750	580	765	950	800	800
Test space volume	Liter	195			332			608		
Loading, max.	kg	130			140			160		
Load per grid	kg	30						40		
Maximum number of grid shelves	Amount	5						7		
Total weight	kg	425	460	490	500	620	680			
PERFORMANCE DATA FOR TEMPERATURE TESTS										
Maximum temperature	°C	+180								
Minimum temperature ¹	°C	-42	-70	-42	-70	-42	-70			
Temperature change speed ² Cooling	K/min	4.0	3.8	4.0	3.8	3.5	3.5			
Temperature change speed ² Heating	K/min	4.0	3.5	3.2	3.0	4.0	4.0			
Temperature deviation ³ over time	K	±0.1 ... ±0.5								
Spatial temperature homogeneity ⁴	K	±0.5 ... ±1.0								
Temperature gradient ⁵		≤2.0								
Heat compensation ⁶ max.	W	2300	2000	2300	2000	2500	3000			
Factory calibration ⁷	°C	+80 and -25 (devices down to -42°C) +80 and -40 (devices down to -70°C)								
CONSUMPTION AND CONNECTION DATA										
Supply voltage	V	3/N/PE AC 400 V ±10% 50Hz								
Nominal power approx.	kW	4.4	5.3	4.4	5.3	6.8	9			
Nominal current approx.	A	13	15	13	15	16	20			
Fuse protection provided by customer	A gG	16			32					
Sound pressure level	dB(A)	56	57	56	57	60	60			
Heat dissipation to the installation room max.	kW	3.7	4.7	3.7	4.7	7.1	9			

Subject to technical changes.

All stated performance data refer to +25 °C ambient temperature, 400 V/50 Hz nominal voltage, without additional equipment.

TECHNICAL DATA | Temperature change rate: 5 K/min

		T2/180/40/5	T2/180/70/5	T2/340/40/5	T2/340/70/5	T2/600/40/5	T2/600/70/5			
DIMENSIONS, LOAD, WEIGHT										
External dimensions (HxWxD) approx.	mm	1830	900	1575	1830	900	1890	2050	1120	1925
Test chamber dimensions (HxWxD) approx.	mm	750	580	450	750	580	765	950	800	800
Test space volume	Liter	195		332		608				
Loading, max.	kg	130		140		160				
Load per grid	kg	30				40				
Maximum number of grid shelves	Amount	5				7				
Total weight	kg	470	540	535	585	620	680			
PERFORMANCE DATA FOR TEMPERATURE TESTS										
Maximum temperature	°C	+180								
Minimum temperature ¹	°C	-42	-70	-42	-70	-42	-70			
Temperature change speed ² Cooling	K/min	8.0	7.5	6.8	6.7	6.5	6.0			
Temperature change speed ² Heating	K/min	8.0	8.0	7.0	7.0	6.0	6.0			
Temperature deviation ³ over time	K	±0.1 ... ±0.5								
Spatial temperature homogeneity ⁴	K	±0.5 ... ±1.0								
Temperature gradient ⁵		≤2.0								
Heat compensation max. ⁶	W	4000	3000	4000	3000	5000				
Factory calibration ⁷		+80 and -25 (devices down to -42°C) +80 and -40 (devices down to -70°C)								
CONSUMPTION AND CONNECTION DATA										
Supply voltage	V	3/N/PE AC 400V±10%50Hz								
Nominal power approx.	kW	7.7	8.6	7.7	8.6	9.9	13			
Nominal current approx.	A	18	21	18	21	18	23			
Fuse protection provided by customer	A gG	32								
Sound pressure level	dB(A)	56	57	56	57	59	60			
Heat dissipation to the installation room max. ⁸	kW	1.2	1.5	1.2	1.5	1.5	2.0			
Heat dissipation to the cooling water max.	kW	8.0	8.5	8.0	8.5	11.5	13.5			
Cooling water connection (supply and return)		Rp 3/4" female thread								

Subject to technical changes.

All stated performance data refer to +25 °C ambient temperature, 400 V/50 Hz nominal voltage, without additional equipment.

1 Temperatures >+5 °C can be run in continuous operation, temperatures <+5 °C can be run intermittently or with additional compressed air dryer equipment.

2 According to IEC 60068-3-5; in the center, in the supply air.

3 In the center of the test chamber in a steady condition, without test specimen, without irradiation and without additional equipment, depending on the temperature.

4 Related to the adjusted setpoint in the temperature range from minimum temperature to +150 °C or at humidities >20 % r.H.

5 Up to +150 °C according to IEC 60068-3-5:2001 or JF 1101-2003.

6 At +20 °C for temperature tests / In the range from +25 °C to +95 °C at a relative humidity of up to 90 % RH for climatic tests.

7 The factory calibration of the temperature and humidity values is carried out with DAkkS-calibrated measuring equipment in the center of the test space and documented using a factory calibration certificate. Optionally, a DAkkS calibration as well as a spatial factory or DAkkS calibration can be performed.

8 For versions with water cooling

BASIC EQUIPMENT

EXTERIOR



External housing	Material	Galvanized steel sheet
	Paint	Light gray (RAL 7035) & anthracite gray (RAL 7016); solvent-free; powder-coated
Door		Single-hand operation, lockable, door hinge left, with LED status bar
Adjustable feet		Adjustable, vibration absorbing

INTERIOR



Test space ¹	Material	Walls: stainless steel 1.4301, surface III D glossy Floor: stainless steel 1.4404, surface II B matt
Insertion system	Made of stainless steel	Rail system for easy change of grid positions incl. M5 female thread for mounting of test setups
Access ports	Made of stainless steel	1 piece right; inner dimension ² : 125 mm Ø 1 piece left; inner dimension ² : 50 mm Ø
Silicone plug	closed	1 piece per stainless steel access port (Ø 125 mm and 50 mm)
Foam silicone plug	slotted	1 piece per stainless steel access port (Ø 125 mm and 50 mm)
Measuring sensor	Temperature	Platinum temperature sensor Pt 100
GreenMode ³	Consumption	Automated energy saving function for constant operation, without air conditioning mode due to shutdown of the refrigeration machine. The energy saving can be up to 30% depending on the test cycle, type and quantity of the test specimen.

REGULATION & CONTROL



SIMPAC®	Digital measuring and control system with I/O unit and WEBSeason® control software, can be controlled remotely through integration into a network
	Operating/programming and monitoring unit with 25.4 cm (10") touch panel integrated in the door, can be folded forward up to 60°

COMMUNICATION



Interfaces	4 digital outputs for controlling customer equipment via floating contacts, max. load 24 V-DC, 0.5 A
	4 digital inputs for feedback signals of customer equipment, max. load 24 V-DC, 30 mA
	1 Ethernet interface (10/100/1000 megabit) for integration into a network
	1 USB interface for direct documentation of measurement data on USB stick ¹

Safety



Test specimen safety	Independent, adjustable temperature limiter t_{min}/t_{max} , sensor installed in test space, individually adjustable fixed value
	Software temperature limiter t_{min}/t_{max} , individually adjustable fixed value
Test chamber fuse	Safety temperature limiter STL for protection against excessive temperature in the test chamber
Test specimen shutdown	Potential-free contact specifically for heat-emitting test specimen, connected to socket, max. load 24 V, 0.5 A

¹ Due to the use of annealed silicone parts, the test space is low in emissions. If the test space is to be emission-free, this will require technical clarification which can be offered on request.

² Production-related tolerances of up to ± 3 mm are possible.

³ Only possible for devices with a temperature range of -70°C to 180°C.

Subject to technical changes!

OPTIONS

INSTALLATION

Mobile version

Mobile base with swivel castors and lockable fixed castors.



Vibration damping feet

Reducing the transmission of vibrations to the floor.

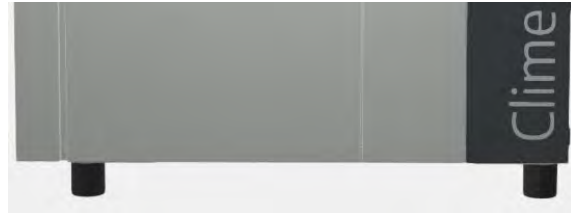

STORAGE PACKAGE

Storage package, small

Two hooks and a magnetic holding rail to store and stow the grid shelves and small test equipment.



Storage package, large

Two hooks and a magnetic holding rail. Additional alternative side panel for the outer housing including a document tray, a tray table and a support rail.



WEBPANEL

Web panel under the door latch

The operating/programming and monitoring unit with 25.4cm (10") web panel is mounted under the door latch.



Web panel in any position on the side

The operating/programming and monitoring unit with 25.4cm (10") web panel can be mounted anywhere on the side panel.

The exact positioning must be specified when ordering.

ACCESS PORTS

Stainless steel access port with silicone plug

Standard (see installation drawing):

- Ø 125 mm at position R1
- Ø 50 mm at position L1

Additional access ports:

- Ø 50 mm
- Ø 80 mm
- Ø 125 mm



Notched access port welded

There is a notched port of about 50 mm x 50 mm in the housing panel on the right for inserting cables.



Access port in the ceiling

Possible access ports:

- Ø 50 mm
- Ø 80 mm
- Ø 125 mm

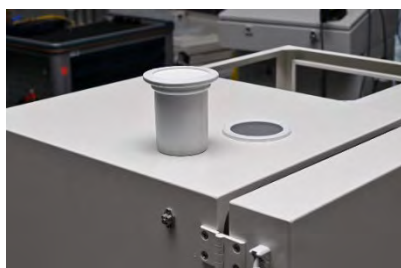

Similar to image

Flat notched port

To feed through individual cables, an insertion piece is inserted into the housing cover, which can be used to feed several cables into the test chamber.



DOOR

Window in the door

Multi-insulated, heated viewing window in the door.

Format: 520 mm x 418 mm.



Door stop right

Version of the device door with door hinge on the right side. The notched port option is not possible. The flat notch port option is possible at the top left.



Test specimen privacy screen

The window pane of the test chamber can be made opaque through a digital switching channel via the light switch.

Note: Only in conjunction with "window in Door" option.



Door seals replaceable for tests with hydraulic oil

If a medium-resistant version for hydraulic oils is required.

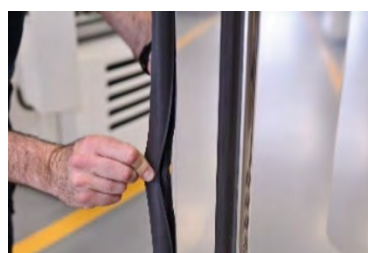

DEMINERALIZATION

Demineralization unit

To replenish water for the humidification device. Pressure resistant up to 6 bar overpressure.

Replacement cartridge for activated carbon filter

Replacement cartridge for activated carbon filter cartridge for the reduction of chlorine content in demineralized water.

Aqua Top pack of 6

Prevents algae growth

Activated carbon filter for demineralized water

Filter housing with activated carbon insert for reduction of chlorine content in fully demineralized water.



TEST SPECIMEN SUPPORT

Drawer on telescopic rails (stainless steel)

Drawer on telescopic rails, can be extended by about 80%. A total of 5 drawers are possible.

Maximum load per drawer: 30 kg



Heavy duty rails

The mass of the test specimen is transferred from the test chamber to the instrument frame via special heavy-duty rails.

Permissible floor load up to 500 kg as surface load.

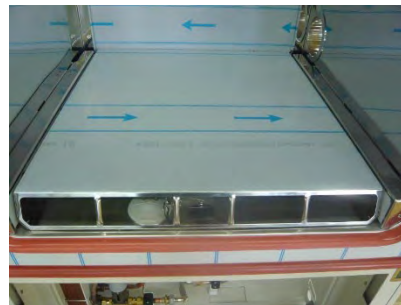

Heavy duty grid shelf

A stainless steel grid placed on the heavy duty rails. *Permissible test space load up to 500 kg as surface load.*



Additional grid shelf

Additional insert grid including support rail for placing test specimens. A grid shelf is included as standard.

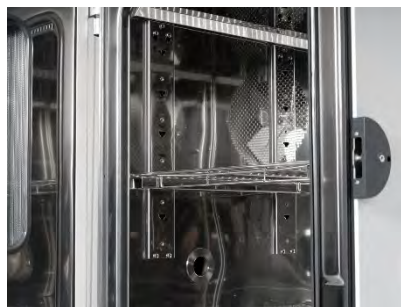

Reinforced shelf

Reinforced shelf, loadable up to 200 kg surface load. The load on the test space as a whole is limited to 280 kg.



DEHUMIDIFICATION

Compressed air dryer regulated for dew points down to -12 °C and -20 °C

For climatic test cabinets, regulated operation down to a dew point of -12 °C is possible. Dehumidification device for climatic test chambers incl. capacitive humidity measuring system for condensation points down to -20 °C with regulated operation.



GN² / Compressed air connection

For operation with a customer-supplied compressed air dryer or for feeding an inert gas into the test space.



RECIRCULATING AIR

Recirculating air volume adjustable

To reduce the amount of recirculated air, the speed of the recirculation fan can be adjusted from 30% to 100%.



CALIBRATION / STANDARDS

Additional factory calibration

Calibration according to specific temperature and climate values.

Standards on request

Various versions are available to meet specific standards.

IQ/OQ Qualification documentation

According to GAMP for SIMPATI software.

AUDI regulations

Marking in accordance with the operating equipment regulations, proof of tightness of the refrigeration circuit, test certificate in accordance with BGV A3, control cabinet with E1 lock, a heating of the test space for 72 hours at 180 °C, a program CD with control data backup, 2x documentation on CD and single documentation in paper form.

DAkkS calibration

Calibration according to DAkkS requirements for specific temperature and climate values.

Modification for Bosch

The adaptation includes the use of the main switch as EMERGENCY OFF, the installation of various information signs, installation of a protective cover, as well as 1 program CD.



Similar to image

TEST SPACE INSTALLATIONS

Stainless steel test space reservoir 1.4404 with stainless steel aluminum evaporator

For increased corrosion protection, the complete test space reservoir is made of high-alloy stainless steel 1.4404 matt.

Note:

This design results in a power loss of approx. 10 % - 15 %.

Sprinkler system

Spray nozzles are installed in the test space through which mineralized water is sprayed into the test space. The equipment can be operated from +5 to +80 °C (without defined humidity) in temperature mode.



IR irradiation equipment

For drying and heating the test specimen by infrared irradiation. Can only be used in a temperature range of +10 to +50 °C and a relative humidity of greater than/equal to 75 %.

Test space low in silicone

For specific tests to reduce the amount of silicone in the test space. Furthermore, the inner door seal is replaced by a Viton seal.

Fan shutdown via digital switching channel

If the digital switching channel is activated, the fan and the temperature control are switched off immediately.

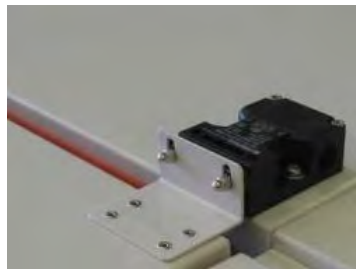

Irradiation equipment for drying tests

For irradiation testing especially in the UV range. Can only be used in a temperature range of +10 to +50 °C and a relative humidity of greater than/equal to 75 %.

Fan switch-off via door contact switch

If the door is opened, the fan and the temperature control are switched off immediately.

SENSOR

Temperature measurement on the test specimen

Movable temperature sensor Pt 100 with flexible cable for temperature measurement at any point in the test space or on the test specimen.



Temperature measurement on the test specimen can be switched over to a control sensor

Switching is performed via a digital switching channel. The measured value can be retrieved via the interfaces or displayed on the control panel.



CONTROL SYSTEM

Additional 4 Digital I/O

Four additional digital inputs and outputs each for controlling additional functions. Four are already available as standard.



Analog value measurement card I/O

For processing and output of analog measuring signals, 5 outputs from 0 to 10 V and 4 inputs for Pt 100 are available.



Temperature range extension up to +200 °C

The test chamber can be extended for a temperature range up to +200°C.

Flexible operation when the program is paused

Function for flexible operation of the test chamber when interrupting the program.

- Digital switching channels can be switched off or on.
- Setpoints can be changed.

Energy meter

Professional energy analysis with a calibrated energy meter. Also in connection with data acquisition via the optional S!MPATI® software. For all units with > 63 A.



SPECIAL VOLTAGE

Special voltage on request

Various special voltages are available.



SAFETY EQUIPMENT

Safety package for Hazard Level 3 - 5

Safety of the test system during tests of lithium-ion energy storage devices by matching EUCAR hazard levels 3 - 5.



ESD-Protection

Potential differences and associated electrostatic discharges onto the test specimen are avoided by means of a common ground. ESD protection can be configured by the customer through various options.



Test chamber release via digital input

The test can only be started if the digital input has a voltage signal or if the adapter plug is plugged into the D-Sub socket Digital I/O.

Door contact switch to indicate that the door is open on the control panel / SIMPATI®

The components of the door contact switch are mounted on the test chamber and on the test chamber door.

When the test chamber door is opened, the message "Door open" appears on the control panel.

2-color signal lamp

The two-color signal light on the test chamber indicates the operating status.

Function indicator:

- green = operating
- red = fault

Electric door tumbler, normally open

The components of the electric door locking device are mounted on the test chamber and the test chamber door. When the test chamber door is opened, the message "Door open" appears on the control panel. The test space door is unlocked at the end of a test, when a test is stopped, in the event of a power failure and when the main switch is turned off.



Electric door tumbler, normally closed

The components of the electric door locking device are mounted on the test chamber and the test chamber door. The test space door cannot be opened during a test, during a power failure and when the main switch is turned off.

Fault signal on potential-free switching contact

If a fault occurs in the test chamber, a potential-free switching contact is actuated.

Emergency stop switch on the test space housing

The emergency stop switch is located on the outside of the test chamber. When pressed, the test is stopped.



COOLING

Water cooling

A water-cooled unit is installed instead of the air-cooled refrigeration unit. A cooling water regulator ensures the lowest water consumption.

Special measures are required for operation with well or pond water, please inquire.



Pump system in the absence of a floor drain

The integrated pumping system pumps the water in the system (condensate, humidification water, cleaning water) against the gradient into a drain provided by the customer.



Hose set for cooling water network

Two flexible hoses are supplied for connection to a cooling water network.



Insulation of the water inlet pipe

Pipes carrying cooling water in the test chamber are also insulated in order to maintain the water supply temperature.



Deep freeze stage with refrigerant R23

Refrigerant R23 is used instead of refrigerant R469A for the deep-freeze stage down to -70 °C.

Electronic cooling water controller

By using an electronically controlled valve, the adjustment to different flow temperatures and pressure differences can be made within certain limits.

Air cooled condenser

Cable length about 1.5 m, extendable up to a maximum of 5 m. Waste heat routed to external condenser. The condenser is on the same level behind the test chamber, horizontal block position with vertical air flow.



THE PRODUCT CONFIGURATOR

Your digital advisor

Configure your desired model to fit your application.

Would you like to customize the new ClimeEvent? This can be done quickly and easily with our product configurator. The online tool guides you through the configuration in just a few steps. Select and combine the options to suit your requirements. Please contact us for more information without obligation or send us your configuration for a quotation.



Simply test it:



DEVICES AVAILABLE AT SHORT NOTICE

Request today - test next week

Extensive pool of stock and rental equipment

These include temperature and climatic test chambers as well as stability test chambers, corrosion test chambers and thermal shock test chambers. Take a look around - the right device for you is just a few clicks away.



Click here for the devices:



STANDARD FINDERS

The right support for every test

Our test chambers are suitable for a wide range of tests.

Various industry and factory standards are safely met. You can find a selection of test specifications and standards by using the specially developed standards finder on our website.

The standards finder will help you find the right product to suit your needs.

Hinzufügen +

Click here to find the right support:



SERVICE

Our approach is to think and act as partners.

We set high standards. Thanks to our service departments, we offer sustainable solutions for long-term reliable plant operation:

- Expert advice with 24/7 helpline
- Maintenance and spare parts management
- Calibration and qualification



More information:



Passionately innovative.

We work in partnership to support companies in research, development, production and quality assurance. With 22 companies in 15 countries at 40 locations.

weisstechnik
For a safe future.



Environmental Simulation

The first choice for engineers and researchers for innovative, safe environmental simulation facilities. In fast motion, our test systems can simulate all the influences in the world as well as for instance in space. In temperature, climate, corrosion, dust or combined stress tests. With a very high degree of reproducibility and precision.



Air Solutions

As the leading provider of clean rooms, climate technology and air dehumidification, we consistently ensure optimal climatic conditions for people and machines. For industrial production processes, in hospitals, mobile operation tents or in the field of information and telecommunications echnology. From project planning to implementation..



Heat Technology

Experienced engineers and designers develop, plan and produce high-quality, reliable heat technology systems for a broad range of applications from heating and drying cabinets to microwave systems and industrial furnaces.



Pharmaceutical Technology

With decades of experience and know-how, we guarantee the most sophisticated clean air and containment solutions. Our comprehensive and innovative range of products includes barrier systems, laminar flow systems, safety workbenches, isolators, airlocks and stability test systems.

Weiss Technik GmbH

Greizer Straße 41-49
35447 Reiskirchen/Germany
T +49 6408 84-0

Beethovenstraße 34
72336 Balingen/Germany
T +49 7433 303-0

info@weiss-technik.com
weiss-technik.com



Click here
to see the product.



Test it. Heat it. Cool it.